

MANUAL DE INSTALAÇÃO CAPOTA MARÍTIMA

MN011CT

Installation Manual Tonneau Cover
Manual de Instalación Capota Marítima

Manual de Instalação MN011CT Rev:00 - 25/08/2017
Installation Manual / Manual de Instalación

Slim
ECO



VEÍCULO VEHICLE VEHICULO					
Cód.	DESCRIÇÃO DESCRIPTION	DESCRIÇÃO DESCRIPCIÓN	Cód.	DESCRIÇÃO DESCRIPTION	DESCRIÇÃO DESCRIPCIÓN
139	STRADA LK CE S'IGAN C'STP 09/2013				
140	STRADA LK CE S'IGAN S'STP 09/2013				
141	STRADA LK CE C'IGAN C'STP 09/2013				
142	STRADA LK CE C'IGAN S'STP 09/2013				
147	STRADA CD S'IGAN C'STP 10/2013				
148	STRADA CD S'IGAN S'STP 10/2013				
149	STRADA CD C'IGAN C'STP 10/2013				
150	STRADA CD C'IGAN S'STP 10/2013				
157	STRADA BAS CD C'IGAN C'STP 10/2013				
158	STRADA BAS CD S'IGAN C'STP 10/2013				

ITEM	QT.	DESCRIÇÃO
Item	Qty.	DESCRIPTION DESCRIPCIÓN
-A-	01	CONJUNTO DE LONA DE VINIL VINYL CANVAS ASSEMBLY CONJUNTO DE LONA DE VINILO
-B-	01	PERFIL DE ALUMÍNIO (BARRA DIANTEIRA) ALUMINUM PROFILE (FRONT BAR) PERFILES DE ALUMINIO (BARRA DELANTERO)
-C-	02	CANTONEIRAS DO TREK TREK CORNER CANTONERAS DEL TREK
-D-	02	VARÕES TENSOSES TENSIONS BAR BARRA DE TENSOSES
-E-	02	PARAFUSOS M5X25 PAN M5X25 PAN SCREWS TORNILLOS M5X25 PAN
-F-	02	PEÇAS DE JUNÇÃO LATERAL LATERAL JOINT SPARE PARTS PIEZAS DE UNIÓN LATERAL
-G-	04	SUPORTES DO VARÃO ROD BRACKET SOPORTES DE VARILLA DELANTERA
-H-	02	PEÇAS DE FIXAÇÃO DIANTEIRA FRONT FASTENING PARTS PIEZAS DE FIJACIÓN DELANTERA
-I-	04	PEÇAS DE FIXAÇÃO LATERAL SEM GANCHO SIDE FASTENING PARTS WITHOUT HOOK PIEZAS DE FIJACIÓN LATERAL SIN GANCHO
-J-	02	PERFIS DE ALUMÍNIO (BARRA LATERAL) ALUMINUM PROFILES (SIDE BAR) PERFILES DE ALUMINIO (BARRA LATERAL)
-K-	02	PARAFUSOS M6X16 M6X16 SCREWS TORNILLOS M6X16
-L-	04	PEÇAS DE FIXAÇÃO LATERAL COM GANCHO SIDE FASTENING PARTS WITH HOOK PIEZAS DE FIJACIÓN LATERAL CON GANCHO
-M-	02	CANTONEIRAS DIANTEIRA FRONT CORNER CANTONERAS DELANTERAS
-N-	02	SUPORTES DO TREK TREK BRACKETS SOPORTES DEL TREK
-O-	01	BORRACHA ESPONJOSA SPONGE RUBBER GOMA ESPONJOSA
-P-	02	PONTEIRAS ABAULADA BULGING TIP PUNTA ABULTADA
-Q-	02	PARAFUSOS M6X30 M6X30 SCREWS TORNILLOS M6X30

FERRAMENTAS NECESSÁRIAS

Necessary Tools | Herramientas necesarias



Chave Allen n°5
Allen Key n°5
Llave Allen n°5



Chave Torx n°25
Torx Key n°25
Llave Torx n°25

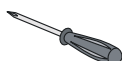

Chave Philips
Phillips Key
Llave Philips

Importante
• Proprietário: Solicite ao instalador instruções de uso e manuseio. Usada corretamente, prolongará a vida útil de sua capota.
• Lave a capota marítima somente com água e sabão neutro, evite produtos químicos. Eles comprometem a resistência da costura e mancham o vinil.
Important
• Owner: ask the installer for using and handling instructions. Correctly using will expand your cover lifespan.
• Wash the cover using only water and mild soap, avoiding chemical products. They compromise the sewing resistance and stain the vinyl.
Importante
• Proprietario: Solicita al instalador instrucciones de uso y manuseo. Usada correctamente, prolongará la vida útil de su capota.
• Lave la capota marítima solamente con agua y jabón neutro, evita productos químicos. Ellos comprometen la resistencia de la costura y manchan el vinilo.

Fone / S.A.C: +55 17 3641-9030

Av. Primo Campagnoli, Nº 1173
Distrito Industrial II

CEP: 15775-000 | Santa Fé do Sul/SP - Brasil

ISO 9001
IATF 16949

BUREAU VERITAS
Certification



/flashcoveroficial

www.flashcover.com.br

- Retirar todos os ganchos da borda e remover o estepe.
- Remover os 2 parafusos centrais da cabine que prendem o protetor de caçamba.
- Remove all of the hooks from the border cargo box and the spare tire.
- Remove the two central screws of the cabin that hold the bed liner.
- Retirar todos los ganchos de amarre del contenedor de la camioneta y el neumático de estepa.
- Quitar los 2 tornillos centrales de la cabina que sujetan el protector de cucharón.

01

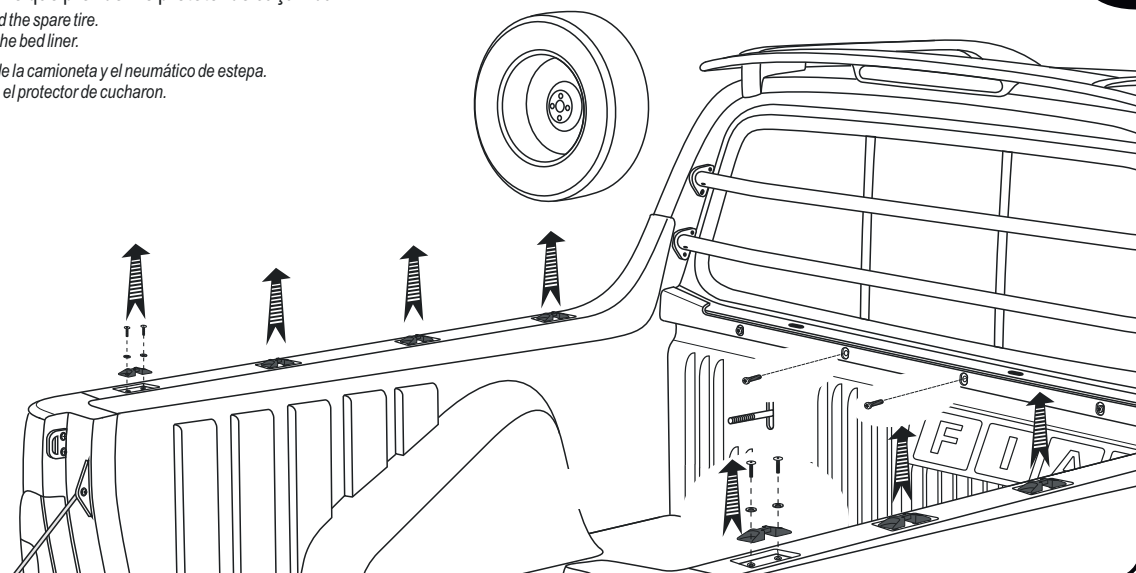
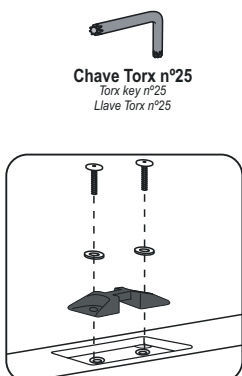

- Fixar os suportes -I- responsáveis pela fixação das laterais com parafuso -Q- que acompanha o Kit.
- Fix the brackets -I- responsible for fixing the sides with the screws -Q- that comes with the kit.
- Fijar los soportes -I- responsables por el fijación de las barras laterales con tornillos -Q- que acompaña al kit.

02

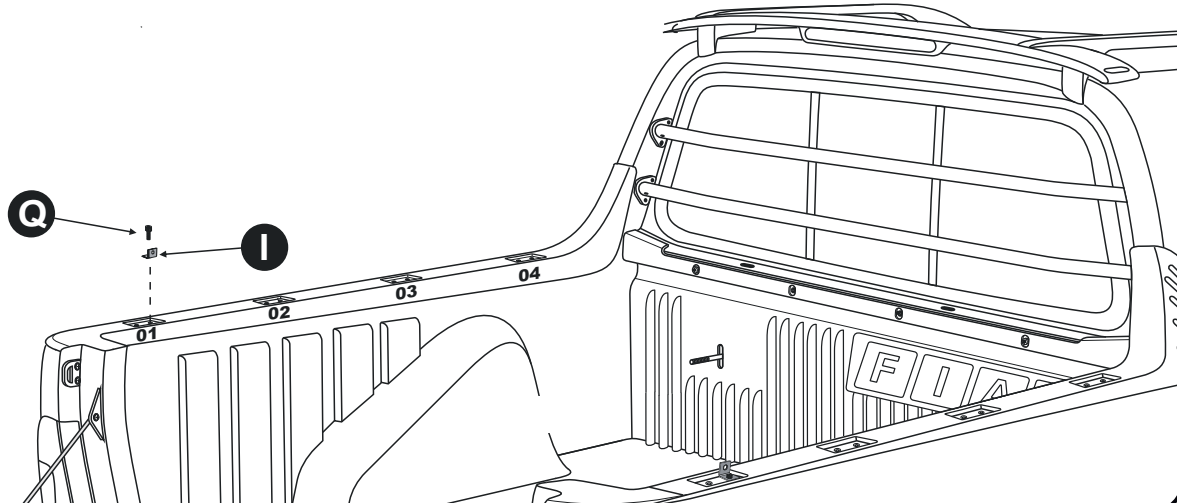

- Unir a barra dianteira -B- com a barra lateral -J- com a peça -F- apertando os parafusos.
- Join the front profile -B- with the side profile -J- with the part -F- pressing the screws.
- Unir la barra delantera -B- y la barra lateral -J- con la pieza -F- apretando los tornillos

03

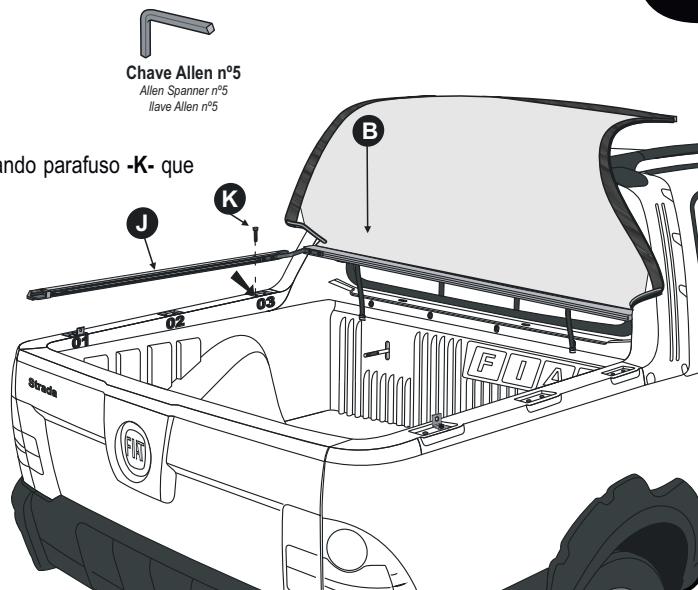
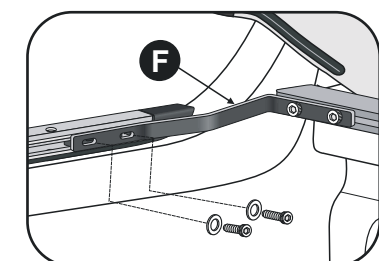

- Alinhar o furo da barra lateral com o segundo furo do gancho nº 04, fixar a barra utilizando parafuso -K- que acompanha o kit.
- Align the sidebar hole with the second hook hole n.04, secure the bar using the screws -K- that comes with the kit.
- Alinear el agujero de la barra lateral con el segundo agujero del gancho nº 04, fijar la barra utilizando el tornillo -K- que acompaña al kit.

- Para fixação do perfil dianteiro **-B-**, utilizar peça de fixação **-H-**, e os parafusos **-E-** que seguem no kit.
- For fixing the front profile **-B-**, use the fixing part **-H-** and the **-E-** screws that accompany the kit.
- Para la fijación del perfil delantero **-B-**, utilice pieza de fijación **-H-**, y los tornillos **-E-** que siguen en el kit.

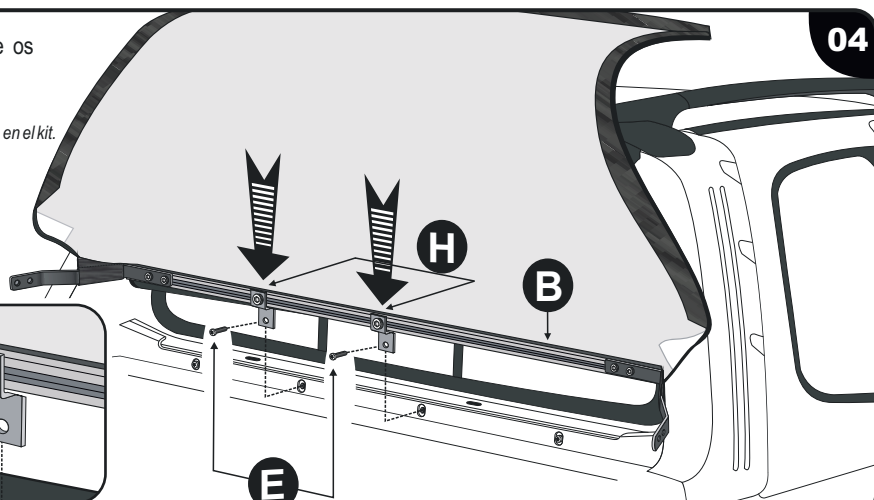
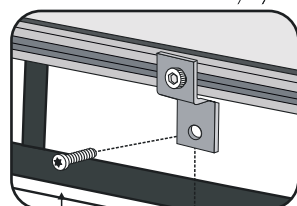

Importante: Para permanência dos GANCHOS, seguir estas instruções como primeiro
Important: To keep the hooks follow these instructions as a first step.
Importante: Para la permanencia de los GANCHOS, siga las instrucciones como primero.

- Instalar perfil dianteiro **-B-** utilizando peça de fixação **-H-**.
- Retirar os ganchos originais da caçamba do veículo, gancho nº 01 e nº 03.
- Install the front profile **-B-** using the fixing part **-H-**.
- Remove the original hooks from cargo box, hooks n.01 and n.03.
- Instalar el perfil delantero **-B-** utilizando la pieza de fijación **-H-**.
- Retirar los ganchos originales del cucharón del vehículo, ganchos n.01 y n.03.

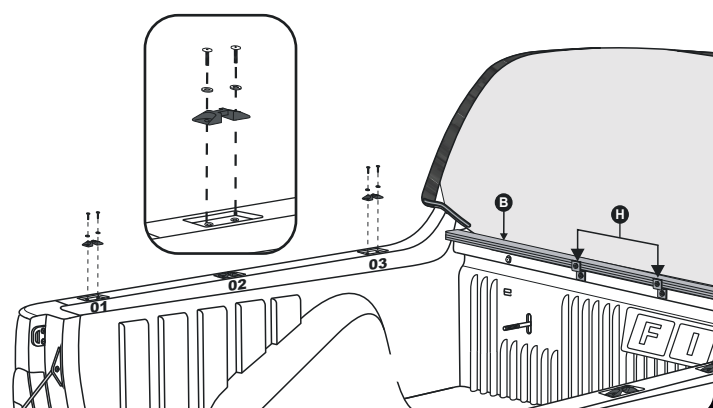
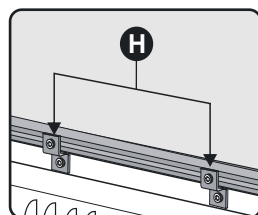

- Encaixar o perfil lateral **-J-** na cantoneira dianteira **-O-**, e posicionar as peças de fixação lateral **-L-** na posição dos ganchos removidos, utilizando os parafusos originais dos ganchos.
- Fit the side profile **-J-** to the front corner **-O-**, and position the side attachment parts **-L-** in the position of the hooks removed, using the original hook screws.
- Colocar el perfil lateral **-J-** en la cantonera delantera **-O-**, y colocar las piezas de fijación lateral **-L-** en la posición de los ganchos removidos, utilizando los tornillos originales de los ganchos.

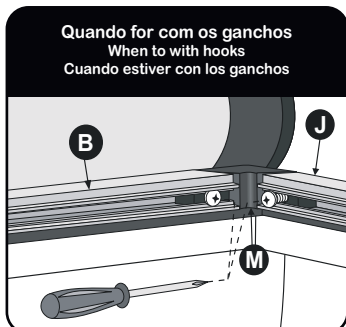

- Encaixar a lâmina plástica da lona **-A-** por baixo da ponteira abaulada **-P-** para um perfeito acabamento sem rugas.
- Fit the plastic blade **-A-** below the bulging tip **-P-** for a perfect finish without wrinkles.
- Encaje la lámina plástica de la lona **-A-** por debajo de la punta abaulada **-P-** para un perfecto acabado sin arrugas.

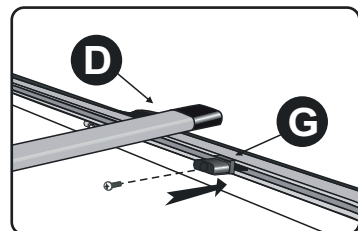
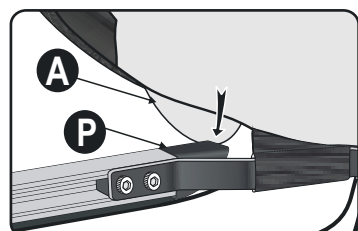

- Posicionar os varões **-D-** e dividir proporcionalmente na caçamba, e apertar os suportes **-G-**.
- Position the rods **-D-** and divide proportionally into the cargo box, and pressing the brackets **-G-**.
- Posicionar los varillas **-D-** y dividir proporcionalmente en el cucharón, y apretar los soportes **-G-**.

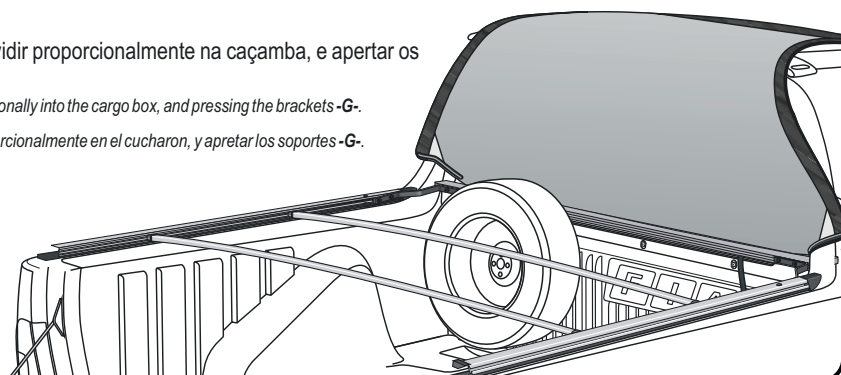

- Verificar se o conjunto de trek está encaixado corretamente.
- Fechar de forma simultânea as duas extremidades da capota.
- Check if the TREK assembly are correctly attached.
- Close both tonneau cover simultaneously.
- Verifica si el conjunto de TREK está encajado correctamente.
- Cierra de forma simultânea las dos extremidades de la capota.

ERRADO
Wrong
Errado

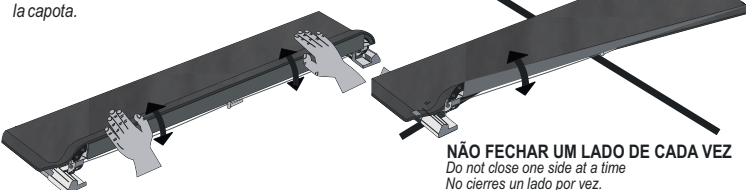

NÃO FECHAR UM LADO DE CADA VEZ
Do not close one side at a time
No cierres un lado por vez.

Lubrificar pinos

e mantê-los lubrificadas

Lubricate pins and keep them lubricated.

Acetilar pinos y mantenerlos aceitados.

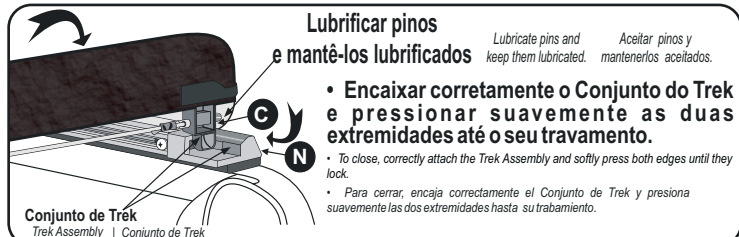

Conjunto de Trek
Trek Assembly | Conjunto de Trek

- Encaixar corretamente o Conjunto de Trek e pressionar suavemente as duas extremidades até o seu travamento.
- To close, correctly attach the Trek Assembly and softly press both edges until they lock.
- Para cerrar, encaja correctamente el Conjunto de Trek y presiona suavemente las dos extremidades hasta su trabamiento.



- Encaixar o Baguete existente na lona **-A-** nos perfis de alumínio **-G-**.
- Encaja el Baguete existente en la lona **-A-** en los perfiles de aluminio **-G-**.

LONA

PERFIL LATERAL

A GARANTIA DAS CAPOTAS MARÍTIMAS É DADA AO PRIMEIRO USUÁRIO NO PRAZO DE:

THE GUARANTEE OF THE COVERS IS GRANTED TO THE FIRST USER WITHIN:

LA GARANTÍA DE LAS CAPOTAS MARÍTIMAS ES DADA AL PRIMER USUARIO EN EL PRAZO DE:

ESTA GARANTIA É VÁLIDA QUANDO:

- a) o certificado estiver devidamente preenchido e no prazo estabelecido;
- b) a capota apresentar: defeitos de fabricação ou de matéria-prima mediante análise do Departamento Técnico, e ou não tenha sido submetida a reparos por terceiros;
- c) após análise da Flash Cover, se for identificado problema de fabricação ou de matéria-prima, reserva-se o direito de trocar, ou consertar apenas a parte ou componente específico do problema, sem direito de o consumidor exigir a substituição total do produto;
- d) não terá Garantia se o produto sofrer acidentes, se for alterada sua condição original ou usada de forma indevida (sem os varões ou demais componentes) ou da montagem inadequada em desacordo com as especificações contidas no Manual de Montagem;
- e) se houver utilização de qualquer produto químico em vez de água e sabão neutro.

THIS GUARANTEE IS VALID WHEN:

Guarantee: The Certificate must be duly filled in and within the established term. Manufacturing and raw materials defect: the replacement of the product will only occur in face of technical department analysis, and in case the product hasn't been subjected to third-party repair. After the technical analysis, once confirmed the problem is due to manufacturing or raw materials, Flash Cover reserves the right to replace or repair only the specific defective part or component, with no right for the consumer to demand the total replacement of the product.

Guarantee does not include: Damages resulting from crashes; loading of cutting and/or bruising materials, or loading materials over the height of the truck bed with closed cover; leaving the cover exposed to concentrated water flow (for ex.: water spout, etc); opening the pack of the cover (Box) using cutting instruments (for ex.: dagger, etc); missing the fixing systems of the cover; part or component breaking due to lack of lubrication (trek set); using the cover not totally close or not totally retracted; incorrect cleaning; improper cleaning; altering of the product original concept; and/or manufacturing serial number removed.

Maintenance, cleaning and durability: for cleaning, use only water, mild soap, sponge or flannel. Never use chemical or abrasive products. Always use the central crossmember that support and facilitate the water draining. Lubricate pins and keep them lubricated.

Guarantee registration: Filling in the Guarantee Certificate.

ESTA GARANTÍA ES VÁLIDA CUANDO:

Garantía: El Certificado debe estar debidamente llenado y en el plazo establecido;

Defecto de fabricación y de materia prima: solo será efectuado el cambio del producto mediante análisis del departamento técnico, y caso lo mismo no tenga sido sometido a reparos por terceros;

Trás el análisis del técnico, si fuera identificado que el problema es de fabricación o materia prima, Flash Cover reserva el derecho de cambiar o arreglar solamente la parte o componente específico del problema, sin derecho del consumidor exigir sustitución total del producto.

Excluyen de la Garantía: Daños causados por colisiones, cargamento de materiales cortantes, contundentes o que sobrepasen la altura del platón del vehículo con la capota cerrada, dejar la capota expuesta en flujo de agua concentrada (ex: canalón de agua), apertura del embalaje (caja) con materiales cortantes (ex: estilete, etc...), uso indebido de los sistemas de fijación de la capota, rotura de piezas por falta de lubricante (set de trek), utilización de la capota sin que esté totalmente cerrada o totalmente recogida, limpieza incorrecta, instalación inadecuada, alteraciones de la concepción original del producto y/o el número de serie de fabricación movido.

Conservación, limpieza y durabilidad: Para limpieza utiliza solamente agua, jabón neutro, esponja o franela. Jamás utiliza productos químicos o abrasivos. Utiliza siempre las traveseras centrales que sostienen y facilitan el desague. Lubrifica los pinos y los mantiene lubricados.

Registro de garantía: Llene el certificado de garantía.